

Palax 55

Instruction manual
Spare parts catalogue

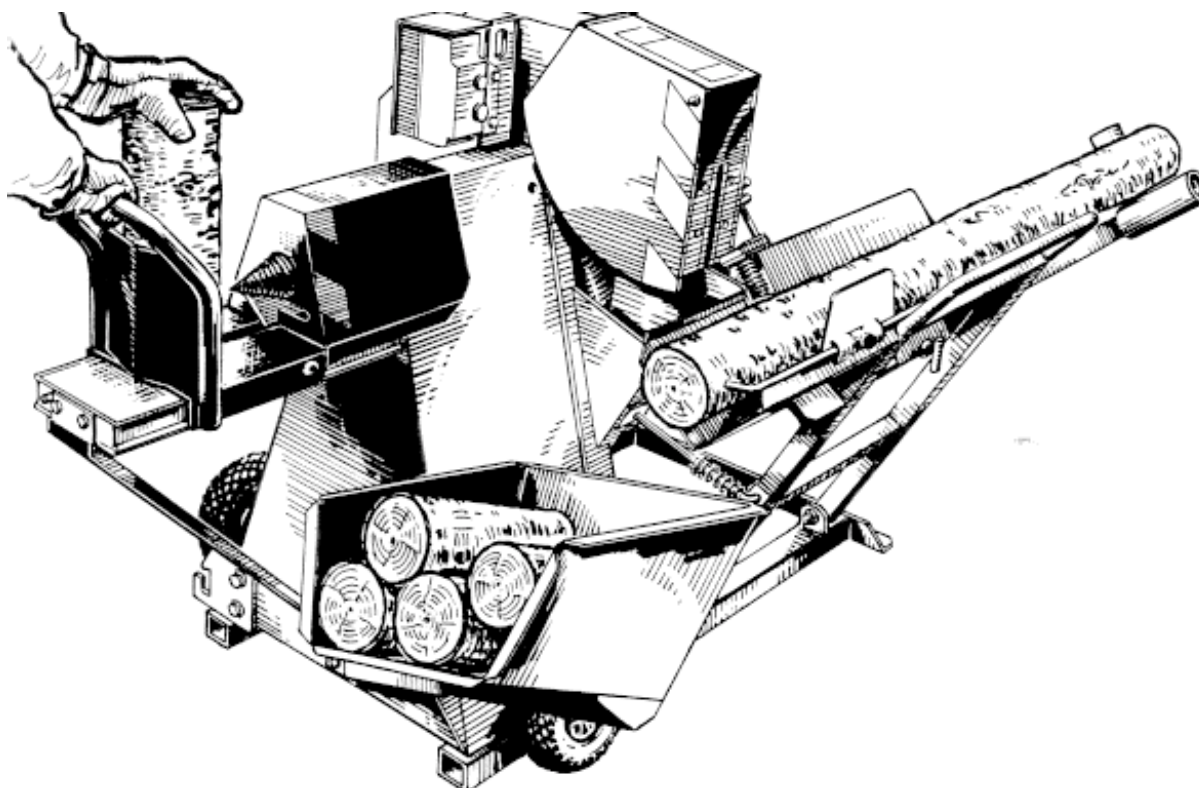

Machine	PALAX 55	Serial No.	Year of manufacture
Type	TR	_____	_____
	3- phase 380V	_____	_____
	PM	_____	_____

1.0	Contents	3
1.1	Foreword	5
1.2	EU Declaration of Conformity	5
1.3	Intended use of the machine	6
1.4	Warning signs	6
1.5	Type markings	6
1.6	Main dimensions of the machine	7
1.7	Safety instructions	7
1.8	Noise emission and vibration	8
1.9	Responsibilities of the operator	8
1.10	Terms of warranty	8
2.0	Taking delivery	8
2.1	Acceptance inspection	9
2.2	Operating conditions	9
3.0	Power source	9
3.1	Powered by a tractor	9
3.2	Stop switch of the tractor-powered machine	9
3.3	3-phase motor	9
3.4	Powered by combustion engine	9
4.0	Using the machine	10
4.1	Measures before crosscut operation	10
4.2	Measures during cutting	10
4.3	Splitting the log	10
5.0	Service	11
5.1	Servicing the crosscut blade (Chrome-Vanadium blade)	11
5.2	Sharpening the chain	11
5.3	Setting the saw-blade	11
5.4	Stressing the saw-blade	11
5.5	Hard-metal blade	11
5.6	Changing the crosscut blade	11
5.7	Tightening the V-belts	12
5.8	Tightening the V-belts (for machine powered by electric motor)	12
5.9	Tightening the V-belts (machine powered by tractor)	12
5.10	Adjusting the stop clutch (tractor-powered machine)	12
5.11	Tightening the V-belts (machine powered by combustion engine)	12
5.12	Servicing the splitting cone	12
5.13	Lubrication and service of the machine	12
5.14	Transportation and storage of the machine	13
6.0	Malfunctions and their remedy	14
7.0	Parts list of the machine	15
	Electric diagram, 3- phase 380V	17

1.1 FOREWORD

Congratulations on purchasing your new PALAX Firewood Processor. The uncompromised aim in the development of this machine has always been high quality, reliability of operation and safety.

We believe that you will be satisfied with this firewood processor, which meets all the essential safety regulations issued by the EU. As proof of this, the CE sign has been affixed to the machine and the EU Declaration of Conformity accompanied by the operator's manual will be delivered with the machine.

Please familiarise yourself with the manual and follow the given operating and safety instructions.

Ylistaron Terästäkomo Oy

1.2 EU Declaration of Conformity

Manufacturer: Ylistaron Terästäkomo Oy
Lahdentie 9
FI-61400 Ylistaro

Product: PALAX 55

- firewood processor equipped with crosscut blade and splitting screw
- powered by tractor, electric motor or combustion engine

Models: TR Powered by tractor
3- phase 380V Powered by electric motor
PM Powered by combustion engine

The following standards have been applied in manufacturing the machine:

SFS- EN 294	Safety distance
SFS- EN 609- 2	Screw splitters
SFS- EN 1553	Power- take-off shafts
SFS- EN 1870- 6	Circular sawing machines
SFS- EN 60204- 1	Electric equipment
SFS handbook	Safety of machines

Notified body: MTT VAKOLA, Vakolantie 55, FI-03400 Vihti

EY- Certificate of Type Approval No. T30/2000

Ylistaron Terästäkomo Oy

Jaakko Viitamäki



Managing Director

1.3 Intended use of the machine

This firewood processor is intended for the purpose of producing firewood of round timber or logs. Use of the machine for any other purposes is prohibited.

Note! Max. capacity of the machine

- For cutting, the maximum diameter of the tree is about 20 cm.
- The maximum length of the log to be processed is 3 metres. If the logs you intend to cut are longer than this, they must only be cut to a length of at most 3 metres or an assistant should be used to prevent the machine turning over.
- Splitting capacity, max. diameter 25 cm and max. length 50 cm

1.4 Warning signs

VAARA- DANGER, on red background, danger of severe injury

- Beware of crosscut saw-blade!
- Beware of splitting screw

VAARA- DANGER, on yellow background, exercise caution, danger of injury

- Release the locking of the crosscut deck before starting the machine

HUOM - CAUTION, on yellow background, read the instruction manual

HUOM - CAUTION, on blue background, directive

- Use eye guards and hearing protectors.

1.5 Type markings

Nameplate on the machine

- The name and address of the manufacturer
- Designation of the machine type
- Serial number and year of manufacture
- Diameter of the circular saw-blade 550 mm
- Diameter of the saw-blade hole 30 mm
- Max 2500 r.p.m.
- Nameplate at the rear of the crosscut saw housing
- Always mention the serial number and year of manufacture when ordering spare parts.

Nameplates on the electric drive

3-phase motor

- Voltage 380 V
- Output 3,0 kW.
- The plate is located at the rear of the blade housing.

1.6 Main dimensions of the machine

Item	Powered by tractor	Powered by electricity	Powered by combustion engine
Output	-	3,0 kW	5,5 hp
Fuse size	-	10 A	-
Weight, kg	150	162	155
Height/width/length	1100 x 800 x 1500		
Crosscut deck	Length 650, with extension table 1500		
Height of crosscut deck	700		
Diameter of blade/hole	550/ 30 mm		
Max. rotation speed of blade	2500 r.p.m.		
Splitting cone, diameter	60 mm		
Max. diameter of tree, cutting/splitting	200 mm/ 250 mm		
Max. length of tree, splitting	500 mm		

1.7 Safety instructions

- Always use eye guards and hearing protectors.
- Do not wear loosely-fitting clothing.
- Danger! Stay away from moving parts.
- Danger! The splitting screw does not stop immediately.
- Always use the feeder for splitting.
- Exercise particular caution when using the splitting screw.
- The machine may only be operated by one person.
- Keep the working space clear of foreign objects.
- Never use the machine indoors. Risk of dust creation!
- Always hitch the tractor-driven machine to the three-point linkage.
- Only use a fault-free power take-off drive shaft and attach the chain for the shaft-guard. Max. 540 r.p.m.
- Only use the stop switch of the tractor-driven machine in case of emergency.
- Keep the exhaust pipe of the combustion-engine-driven unit at a safe distance from anything that might catch fire! Danger of fire!
- Beware of the hot exhaust pipe on the combustion-engine-driven unit!
- Always stop the engine for refuelling.
- Only operate the machine in an adequately lit space.
- Make sure that all other people stay outside the operating range.
- The machine is exclusively intended for the purpose of cutting and splitting firewood.
- The maximum length of the log to be cut is 3 metres. Danger of turning over!
- Only cut one tree at a time.
- During the cut-off operation, make sure that the tree is always supported by the support rollers of the crosscut deck: danger of rolling over!
- Exercise particular caution when cutting knotty or crooked trees, because, as a result of faulty cutting, the tree might roll over or twist the saw-blade with a force that breaks or splits the blade.
- Carelessness during the cut-off operation constitutes a serious danger!
- Always stop the machine before servicing.
- Never remove any safety-related devices from the machine.
- Always ensure that the electric conductors are intact.
- Always release the locking of the crosscut deck before operating the splitting device.

1.8 Noise emission and vibration

- The A-weighted sound-pressure level at the workstation is 90,5 dB (A) and the sound power level is 105.0 dB (A).
- The 0,4 m/s² vibration (acc. to ISO 5349) subjected to the operator's hands does not exceed 2,5 m/s².

1.9 Responsibilities of the operator

- The machine may only be used to produce firewood.
- All the safety-related devices are necessary to ensure a sufficient level of safety.
- The PALAX is a very safe machine provided that the instructions supplied are properly followed, the regular maintenance routines are duly executed and the work is carried out without haste.
- The machine operator is responsible for the flawless operation of the safety-related devices and for ensuring that the machine is serviced in a due manner.
- The operator is responsible for ensuring that no one else is subjected to any danger.
- Modifying the construction of the machine is prohibited.

1.10 Terms of warranty, PALAX 55

- The warranty period runs for 12 months from the date of purchase.
- Consult your dealer or the importer about matters related to the warranty.
- A new part is delivered to compensate the defective one.
- The warranty does not cover defects due to normal wear, faulty operation or negligent maintenance.
- The warranty does not cover blade defects resulting from improper sawing procedures.
- The warranty does not cover V-belts, filters or oils.
- The obligations under warranty for the combustion engine lie with the manufacturer of the engine.

2.0 Taking delivery

The machine packed in an upright position on a pallet

- Remove the plastic shroud covering the machine.
- Take away all loose parts from the package.
- Turn the machine into the horizontal position.
- **WARNING!** The machine weighs over 100 kg. Two people are required to turn the machine.
- Remove the transportation pallet.
- Remove the transportation pallet only after the machine has been turned into the transport position.
- The combustion-engine-driven machine is always delivered without engine oil. The oil is in a separate package.
- The machine has been test run and all the initial settings have been completed.
- Check and, as required, change the direction of rotation of the model powered by electricity.
- The machine is fixed to the pallet at three points.

2.1 Acceptance inspection

- In order to save on freight expenses and to avoid damage during transportation, the machine is delivered partly dismantled, with all the protruding parts such as the extension table and log box removed and packed separately.
- Check the delivered goods without delay.
- If the product shows evidence of transport damage, contact your dealer immediately.

2.2 Operating conditions

- ❑ Never use the machine indoors, owing to the risk of dust generation or exposure to exhaust gases when the unit is powered by a combustion engine.
- ❑ Only operate the machine in an adequately lit space.
- ❑ Prevent risks, such as slipping in winter, by organising the work site in a due manner.
- ❑ Make sure that no other people, especially children, are present inside the operating range.
- ❑ Always bring the machine to a horizontal position.

3.0 Power source

3.1 Powered by a tractor

- ❑ Always hitch the machine to the three-point linkage of the tractor.
- ❑ A suitable size for the power-take-off shaft is, for example, a BONDIOLI A3 or equivalent.
- ❑ Always use a faultless power-take-off shaft and attach the anti-rotation chain to the machine (max. rotational speed is 540 r.p.m.).
- ❑ When disconnecting the power-take-off shaft from the tractor, support it using the hook on the machine.
- ❑ If the power-take-off of the tractor has a high-speed range, then use it. Ensure, however, that the rotational speed of the power-take-off shaft does not exceed 540 r.p.m.

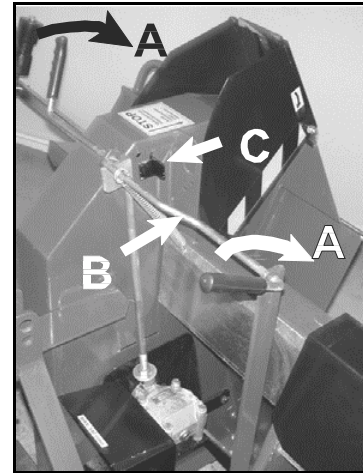

3.2 Stop switch of the tractor-powered machine (Figure 3)

- ❑ The machine is equipped with a stop switch and a friction brake.
- ❑ To loosen the belts between the blade shaft and the angular gear, pull the clutch lever B in the direction of the arrow. At the same time, the clutch lever presses the friction lock lever C against the side of the crosscut blade, making the blade stop.
- ❑ **Because the clutch is only intended for emergency stopping, the clutch lever B has to be turned to the rear in the running position, before starting up the circular saw.**

Fig. 3

3.3 3-phase motor, output 3,0 kW

- ❑ The machine is equipped with 5-m-long conductor with five leads and a 16-A plug.
- ❑ At start-up, ensure that the motor is running in the right direction in accordance with the arrow. If the circular saw is rotating in the wrong direction, then switch the positions of the two phases in the plug. If you absolutely do not know how to do that, leave it to a professional.

3.4 Powered by combustion engine, Honda, output 5,5 hp

- ❑ **NOTE! Check the engine oil level.**
- ❑ Use 95-octane unleaded petrol in the combustion engine. Always stop the machine for refuelling.
- ❑ Take care not to spill petrol on the hot engine (danger of fire).
- ❑ Read the Instruction Manual for the engine carefully.

Start-up of the combustion engine (Fig. 5)

- ❑ Pull out the stop button A for the engine.
- ❑ Open the fuel cock (see the Honda manual).
- ❑ Turn on the choke.
- ❑ Turn down the clutch lever B for the V-belts.
- ❑ Turn the gas lever to about half-way and start the engine.

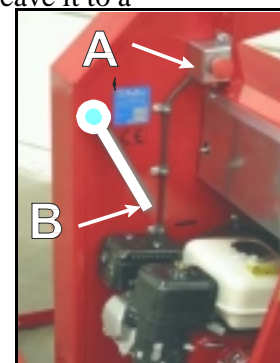

Fig. 5

- ❑ Immediately after starting, turn the lever B in the position as shown by Fig. 6. Then the V-belts tighten and the blade starts rotating.
- ❑ Turn off the choke and apply full engine speed.
- ❑ The max. engine speed has been adjusted to that suitable for the circular saw.

Stopping

- ❑ Shift the gas lever to idling.
- ❑ Switch off the engine and shut the fuel cock.
NOTE! Only loosen the V-belt for starting. Tighten the belts using the lever B as soon as the engine starts running smoothly.
 In connection with repair and maintenance work on the combustion engine, take care not to increase the engine revolutions and thus make the speed of the saw-blade exceed 2500 r.p.m.



Fig. 6

4.0 Using the machine

4.1 Measures before crosscut operation

- ❑ Clean any protective grease off the new saw-blade.
- ❑ Note! A greasy blade accumulates resin easily, making it heat up, lose its tension and start to wobble.
- ❑ Never cut trees over 3 metres in length on your own. Danger of rolling over!

4.2 Measures during cutting

- ❑ Always position the log on the deck so it is supported by the grooved rollers next to the crosscut blade.
- ❑ Press the log smoothly against the crosscut blade and, at the same time, hold it with your other hand.
- ❑ Always cut the logs into the log box.
- ❑ Exercise caution, always keep your hands away from the saw-blade.
- ❑ Do not cut slender trees more than two at a time, because if many trees are cut at the same time, some of them may twist the blade strongly, thus making it lose its tension.
- ❑ Never stop the rotation of the blade by pressing wood against its side or its teeth.
- ❑ During the crosscut operation, make sure that the log is always supported on the roller at the cutting point.

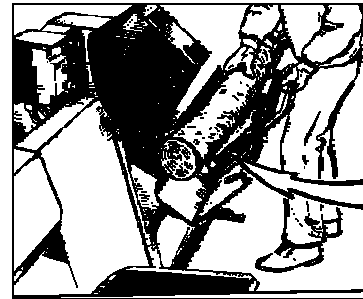

Fig. 7

Fig. 7. Wrong, the log is not supported by the rollers

4.3 Splitting the log (Fig. 8)

- ❑ Always place the log to be split in an upright position on the splitting device.
- ❑ Push the end of the log down with one hand and push the log against the splitting screw for splitting using the splitting deck lever with your other hand.
- ❑ Keep on pushing until the log splits.
- ❑ If the log is tough and does not split, you can release it by pulling back the lever.
- ❑ **Always exercise particular caution when near the splitting screw!**

Fig. 8

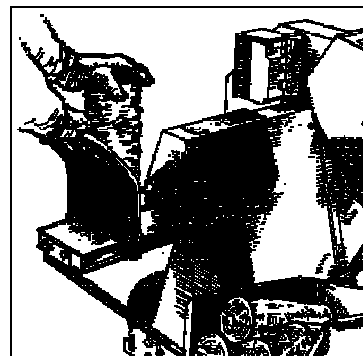

5.0 Maintenance of the machine

5.1 Servicing the crosscut blade (ordinary Chrome-Vanadium blade)

- Check the saw-blade setting, 1-1,2 mm for fresh wood, 1,4-1,6 mm for dry wood.

Note! A blade without setting heats up and requires a lot of driving power.

5.2 Sharpening the chain

- The saw-blade can be sharpened several times without removing it from the machine. Use a fine-cut square-blade file of 8-12" for sharpening.
- Support the blade for sharpening by, for example, a wooden wedge to prevent its vibration.
- Press the file against the blade only during the sharpening stroke, because the sharpest ribs of the file can break easily during the return stroke and the file becomes "glazed".
- During manual sharpening, only file the front rake of the tooth over a distance of about 5-7 mm.
- Always keep the original shape of the tooth.
- Do not make sharp notches at the root of the tooth with the file.
- File each tooth as much.
- Always clean the blade-flanges carefully.
- Check the blade carefully to ensure you are never sawing with a cracked blade.

5.3 Setting the saw-blade

- Use a saw setting key.
- The setting shall be about 0,5-0,8 mm/side, and about 1/3 measured from the tip of the tooth.
- Set the saw to equal length on both sides and make sure that the setting comes in the right way.
- A hard-metal blade does not require setting, as the bit is slightly wider than the blade-flange.

5.4 Stressing the saw-blade

- If the blade gets too hot, it loses its tension.
- This makes the blade wobble. Stop sawing immediately!
- If, after cooling down, the blade again starts wobbling, check its setting and sharpness. If these are in order, the blade must be forged.
- If you cannot do that yourself, assign a skilled professional.

5.5 Hard-metal blade

- A hard-metal blade does not require setting, as the hard-metal bit is slightly wider than the blade-flange.
- Always sharpen the blade using a sharpening machine with a grinding disk intended for hard-metal.
- The blade has a long sharpening interval, which means it can cut several hundreds of cubic metres of firewood between sharpenings. If the sawing noise gets louder, the blade must be sharpened.

5.6 Changing the crosscut blade

- Remove the protective housing A for the crosscut blade (Fig. 9).
- Remove the side blade B of the housing.
- Twist an M12 bolt into the thread hole in the counter-flange to prevent the shaft from rotating.
- Twist open the blade nut (right-hand thread M24x2, 36-mm wrench).
- Clean the counter-surfaces of the blade-flanges carefully before re-installation of the blade.

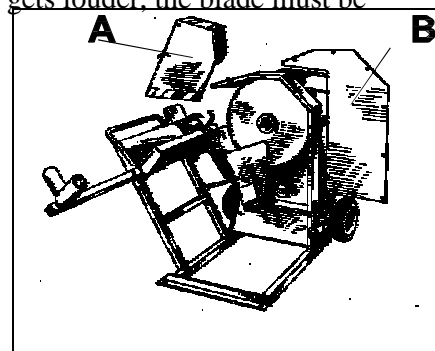

Fig. 9

5.7 Tightening the V-belts

The V-belt of a new machine must be re-tightened after a few hours of operation.

5.8 Tightening the V-belts (for machine powered by electric motor)

- Loosen the attachment screw A on the motor rack (Fig. 10).
- Tighten the screw under the blade housing.
- Check the tightness of the V-belt through the opening C in the side of the blade housing (Fig. 8) using, for example, a screwdriver. The tightness is suitable as the belt sags about 10 mm when depressed by a force of about 2 kg.
- Tighten the attachment screw on the motor rack.

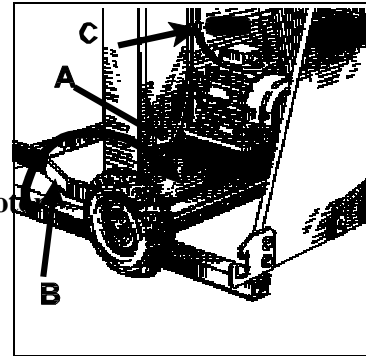

Fig. 10

5.9 Tightening the V-belts (machine powered by tractor)

- The clutch lever A must be in the rear position, i.e. the belts must be tight, during tightening.
- Loosen the nut B at the lower end of the clutch rod (24-mm wrench).
- Tighten the upper nut C.
- Check the tightness of the V-belt, for example, by using a screwdriver to apply a force of about 2 kg to push the belts through the opening A in the side of the blade housing (Fig. 12).
- The tightness is deemed suitable when the belt sags by about 10 mm.
- Tighten the nut B (Fig. 11)

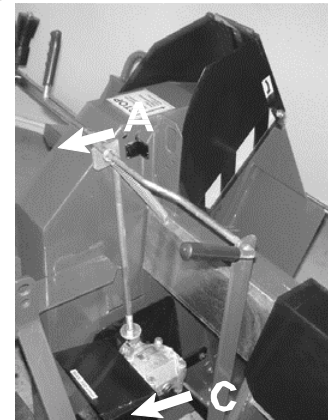

Fig. 11

5.10 Adjusting the stop clutch

- If the tension of the V-belts is correct, then the adjustment of the clutch is also right.

5.11 Tightening the V-belts (machine powered by combustion engine)

- The clutch lever B (Fig. 6) must be in the rear position, i.e. the belts must be tight, during tightening.
- Loosen the nut B at the lower end of the clutch rod (19-mm wrench).
- Tighten the upper nut A.
- Check the tightness of the V-belt, for example, by using a screwdriver to apply a force of about 2 kg to push the belts through the opening A in the side of the blade housing (Fig. 12).
- The tightness is deemed suitable when the belt sags by about 10 mm.
- Tighten the nut B (Fig. 13)



Fig. 12

- Adjustment screws at the lower end of the clutch rod for tightening of V-belts.

5.12 Changing the V-belt

- Remove the protective housing for the crosscut blade
- Remove the side plate of the crosscut blade housing.
- Remove the crosscut blade
- Loosen the V-belts.

- Remove the worn belt and put a new belt in place.
- Tighten the belt. Do not forget to re-tighten the new V-belt after a few hours of operation and always when required (belt type A 13 x 1100).



Fig. 13

5.13 Servicing the splitting cone

- The tip of the splitting cone is replaceable (left-handed thread M24).
- The tip has a double-headed thread that can be sharpened using a round saw-chain file.

5.14 Lubrication and service of the machine

- Lubricate the shaft bearings with roller bearing grease preferably at the end of each operating season. Then the bearings will remain filled with new grease, which prevents the bearing surfaces from coming into contact with moisture.
- The roller bearings on the splitting deck are lubed-for-life. They do not need any lubrication.
- Wash the machine carefully once you stop using it.

5.15 Transportation and storage of the machine

- Transfer of the machine is really easy using the 25-cm-diameter wheels, which are a standard feature in machines powered by electricity or combustion engine (Fig. 10).
- Grip the turn lever B of the shaft firmly and turn the machine into the operating or transportation position.
- The machine must be firmly tied down for transportation on, for example, a light motorcar trailer.
- Never store the machine out of doors, because its sensitive electric appliances may get damaged.

6.0 Malfunctions and their remedy

Malfunction	Cause	Remedy
Crosscut blade is heavy on power and gets hot	<ol style="list-style-type: none"> 1. Blade is blunt. 2. Setting too small. 3. Too much resin in the blade. 	<ol style="list-style-type: none"> 1. Sharpen the saw-blade. 2. Set the blade. 3. Clean the blade.
Crosscut blade wobbles. Blade starts wobbling after a short period of operation	<ol style="list-style-type: none"> 1. Impurities between the flanges. 2. Setting too small, pre-stressing faults. 	<ol style="list-style-type: none"> 1. Clean the flanges and the blade. 2. Set the blade. Pre-stress the blade by forging.
Blade whines	<ol style="list-style-type: none"> 1. Speed too high 2. Tooth cracked at the root 	<ol style="list-style-type: none"> 1. Lower the max. revolutions of power take-off shaft to 540 r.p.m. 2. Do not operate. Replace blade.
Crosscut blade rotates in wrong direction.	1. Phases of an electrically driven machine are in the wrong positions	1. Switch positions of two phases.
Electric motor does not start.	<ol style="list-style-type: none"> 1. Emergency stop button epressed. 2. Makes a loud noise. but does not start 	<ol style="list-style-type: none"> 1. Reset the emergency stop. 2. Fuse blown. Replace fuse.
Motor stops several times and thermo-relay trips.	<ol style="list-style-type: none"> 1. Blunt blade, heavy on power. 2. Incorrect setting of thermo-relay 	<ol style="list-style-type: none"> 1. Sharpen the blade. 2. Re-adjust the thermo-relay.
Splitting cone does not pull the log	1. Blunt tip	1. Sharpen the tip
Whining sound during sawing and splitting operations	V-belts slack.	Tighten the belts.

7.0 Main parts of the machine and spare parts list

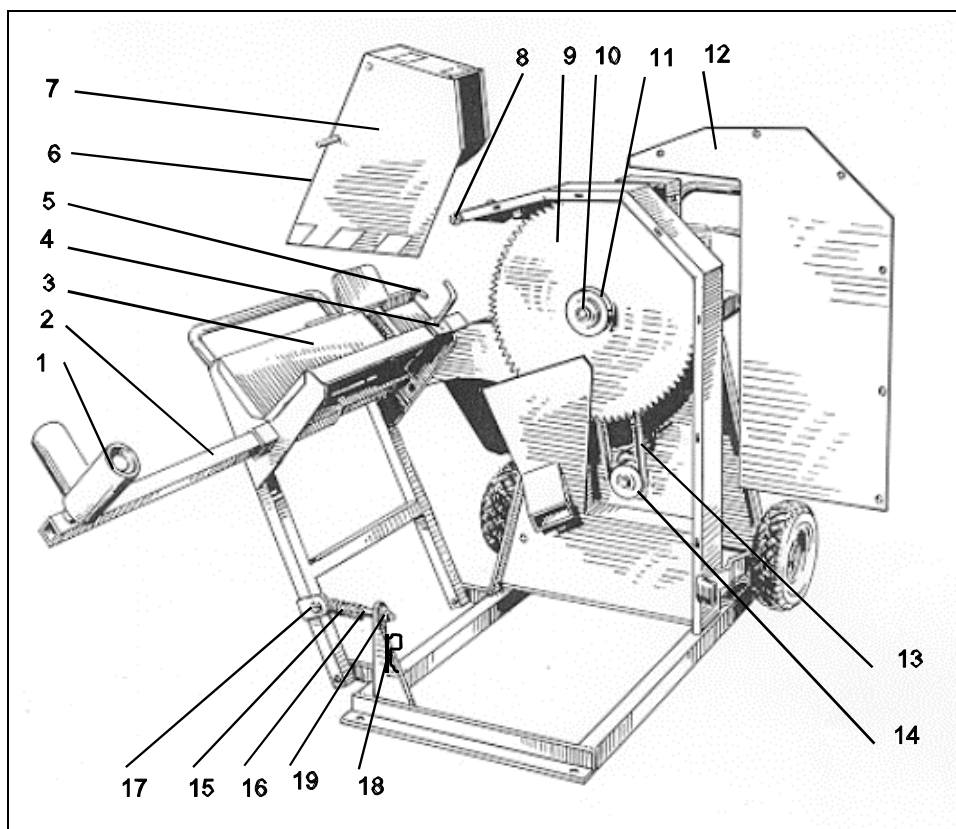

Fig. 13

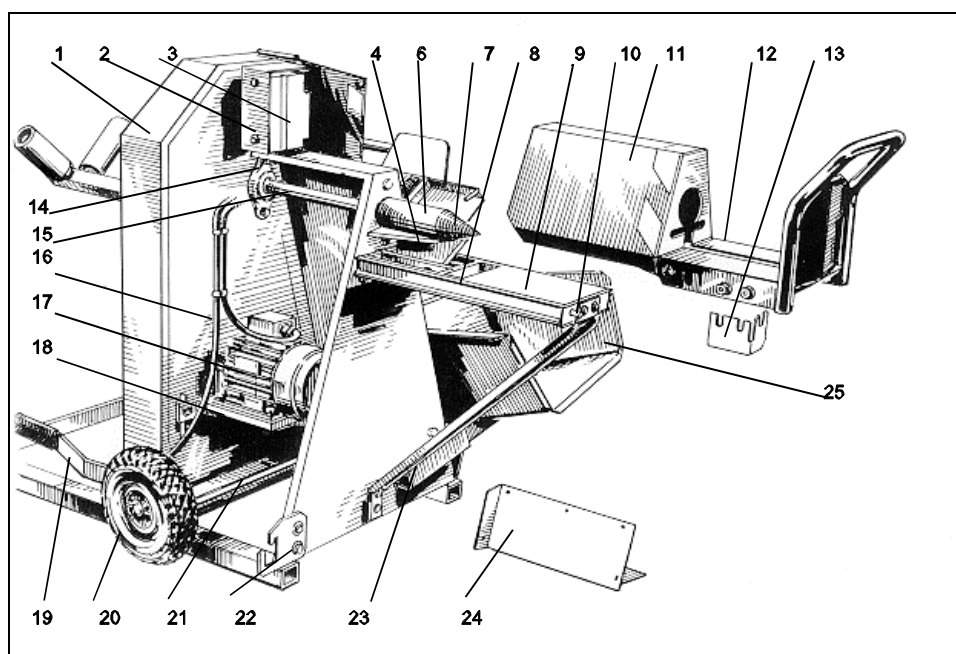

Fig. 14

Fig.	Part	Item	Order no.	Fig.	Part	Item	Order no.
13	I	Plastic pipe	5515-030	14	6	Splitting cone	5-26-010
13	2	Support deck	5515-001	14	7	Tip part	5526-020
13	3	Deck	5512-001	14	8	springSpring	5518-070
13	4	Glide blockGide block	5512-170	14	9	Slide frame	5518-001
13	5	Length indicator	5512-320	14	10	Spring guide	5518-060
13	6	Plastic cover	5-20-0-0	14	11	Slide	5-16-001
13	7	PrpTECTIVE housingProtective cover	5520-001	14	12	Bearing 6202-RS	5517-001
13		Bearing FL 206	5511-130	14	13	Spring holder	5518-120
13	9	Bit, Chrome-Vanadium	5525-010	14	14	Bearing	5521-080
13	9	Bit, hard-metal	5525-015	14	15	Shaft	5521-001
13	10	Nut M 24 x 2.	5-21-0-0	14	16	Conductor, 3-phase	5-40-0-0
13	11	Flange	5-21-040	14	17	Motor, 3-phase	5-40-010
13	12	Side plate	5511-040	14	17	Combustion engine	5550-010
13	13	V-belt. all models IA 11301 A43	5521-060	14	18	Motor rack	5-22-001
13	14	Belt pulley, 3 electric mot.	5540-020	14	19	Lever	5523-070
13	14	Belt pulley, combustion engine	5550-020	14	20	Wheel, solid rubber	5523-010
13	15	Spring	5-27-0-0	14	21	Shaft	5-23-020
13	16	Back stop	5527-010	14	22	Locking plate	5523-110
13	17	Split cotter 4 mm	5527-020	14	23	Support beam	5518-160
13	18	Roll pin 5 mm	5-27-030	14	24	Shaft cover	5-11-230
13	19	Attachment chain for pin	5527-040	14	25	Log box	5524-001
14	2	Attachment plate	5-40-080				
14	3	Starter, 3-phase	5540-030				
14	4	Splitting wedge	5519-001				
14	5	Locking screw	5526-030				

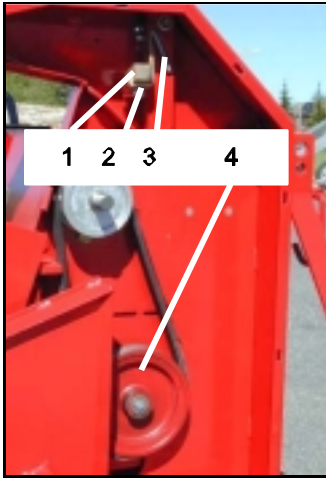

Fig. 15

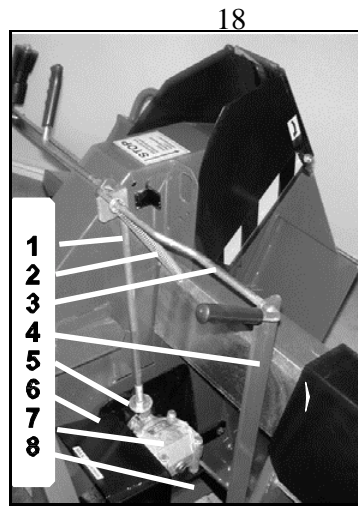

Fig. 16

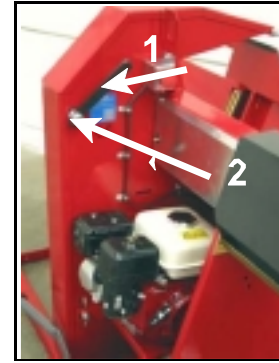

Fig. 17

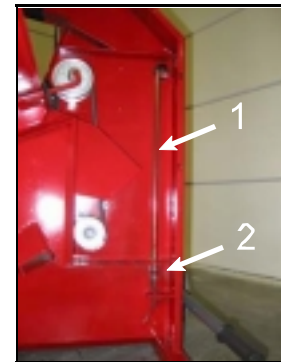

Fig. 18

Fig.	Part	Item	Order no.	Fig.	Part	Item	Order no.
15	I	Friction part	OYI80173	16	5	Shaft	01206090
15	2	Lever	5526080	16	6	Prptective housingProtective	15526050
15	3	Spring	OJVI01168	16	7	Angular gear	5530015
15	4	V-belt pulley	5530025	16	8	Angular gear rack	5522006
16	I	Push rod	5528001	17	1	Clutch lever	15522200
16	2	Spring	OJV2520130	17	2	Eccentric shaft	5522150
16	3	Clutch lever	5-29001	18	1	Clutch rod	15522300
16	4	Support plate	5529005	18	2	Bushing	5522140

NOTE! Always mention the serial number and year of manufacture of the machine while ordering spare parts.

