



KIOTI COMPACT TRACTOR
CK20S/CK27/CK30/CK35



Distinctive design

The curved hood and fender add distinctive lines to the CK Series tractors.



The **CK Series** line of 20 hp to 35 hp distinctively designed compact utility tractors is available in Hydrostatic or manual transmission. Loaded with features and an ultra-quiet, low vibration, environmentally friendly Daedong diesel engine. All CK series tractors feature suspended brake and clutch pedals to maximize the operator platform for ease of movement by providing more space.



Hydrostatic Transmission

The CK20SH, CK27H, 30H and CK35H feature performance proven, heavy-duty Hydrostatic drives that deliver power smoothly and efficiently.

HST Pedal

A single pedal control allows speed and direction changes without clutching. With the Kioti HST drive system, your hands remain free for steering and implement control.

High Capacity Hydraulic Pump

The high capacity, efficient tandem hydraulic pump gives you smoother handling in heavy duty working conditions and helps reduce working time and improve job efficiency. (CK27,CK30,CK35 only)



Environmentally Friendly Engine

The optimized combustion diesel engine is environmentally friendly and meets or exceeds EPA, CARB, and EEC regulations. It supplies a large output, offers low fuel consumption, greater durability, and creates less noise and low vibration.



Simple Maintenance

Kioti tractors are especially designed for easy maintenance. Lifiable hoods and removable side panels allow easy access for daily service checks. Both the air filter and fuel filter are conveniently located. Kioti makes it easy to maintain your tractor for long life and high performance.



Cooling System

A high capacity radiator prevents engine overheating during operation. The cooling fan increases the air flow into the radiator even at low speed. A removable radiator screen prevents dust and debris from entering the radiator.

Rugged dependability in the CK series tractor



Spring Lever Operated Tilt Steering Wheel

A simple pull of the lever lets you adjust the wheel to your comfort. (CK27, CK30, CK35 only)



Single Lever Joystick

All front loader functions are easily controlled by a single lever joystick comfortably located at the right waist level. When released, the control automatically returns to neutral, leaving the loader in the desired position. A float function allows the bucket free-floatation over the ground surface.



Power Steering

Responsive, powerful and comfortable steering reduces operator fatigue. The power steering system is robustly designed for maneuvering in soft soil and for front loader operation.



Comfortable Seat with Suspension

With a high quality adjustable seat with suspension, the user enjoys a comfortable and smooth ride. The retractable seat belt is included for safety.





“ I’ve been a tractor owner and operator for many years. My new KIOTI is the best investment I’ve ever made.”



Parking Brake and Cruise Control Levers

Conveniently located parking brake (red lever) and cruise control (yellow lever) levers are in easy reach of the operator. Cruise control is only available on HST models.



Foldable ROPS

A fold-down roll bar makes it quick and easy to move in a low clearance areas.



Rear PTO

Rear PTO is standard on both Gear & HST tractors. You can select the rear PTO or the optional mid PTO separately or simultaneously. This allows the use of various implements, including a mid-mount mower.

3 Point Hitch

With an adjustable right side lift rod and top link, you can easily attach implements.





Loader Model : KL130 Tractor Model : CK27/CK30/CK35

Front End Loader

The KIOTI KL120 and KL130 front end loaders are specifically designed for the CK series tractors, providing efficient performance with single lever joystick control. The KIOTI loader, with a built in parking stand, is designed to be quickly and easily attached and detached. KL Series loaders utilize the tractor's hydraulic system, feature single-lever control with float and come with a bucket level indicator.

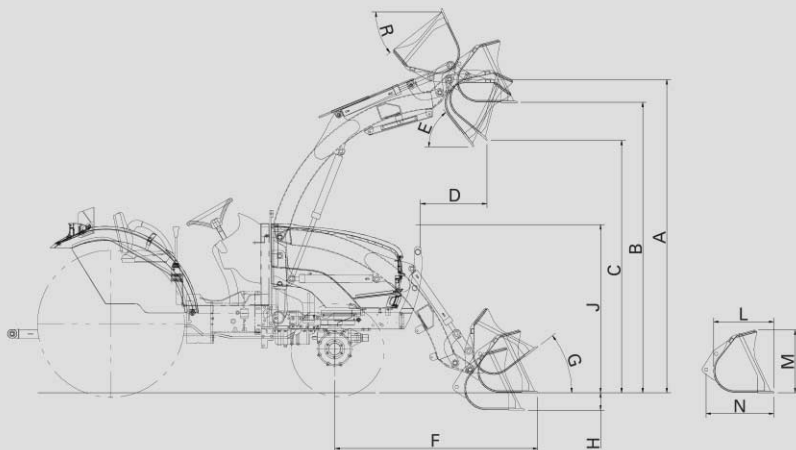

Loader Specifications

	KL120	KL130
A. Maximum Lift Height	2,236mm(88.0")	2,350mm(92.5")
B. Clearance with Attachment Level	2,063mm(81.0")	2,177mm(85.7")
C. Clearance with Attachment Dumped	1,756mm(69.13")	1,870mm(73.6")
D. Reach at Maximum Height	489mm(19.25")	452mm(17.8")
E. Maximum Dump Angle	45°	52°
F. Reach with Attachment on Ground	1,381mm(54.37")	1521mm (59.88")
G. Maximum Rollback Angle	35°	37°
H. Digging Depth Below Grade	73mm(2.87")	135mm (5.31")
J. Overall Height in Carry Position	1,053mm(41.46")	1,260mm (49.60")
L. Depth of Attachment (to back of inner shell)	450mm(17.71")	450mm (17.71")
M. Height of Attachment	470mm(18.50")	470mm (18.50")
N. Depth of Attachment (to pivot pin)	507mm(19.96")	507mm (19.96")
R. Over Tilt Degree	47°	38°
S. Lift Capacity to Full Height at Pivot Pins	488kgf (1,076 lbs)	525kg (1155 lbs)
T. Breakout Force at Pivot Pins	687kgf (1,515 lbs)	930kg (2046 lbs)
Lift Cylinder	ø 45mmX550mm (ø 1.77X21.65")	ø 45mmX612mm (ø 1.77X24.09")
Bucket Cylinder	ø 45mmX589mm (ø 1.77X23.19")	ø 45mmX589mm (ø 1.77X23.19")
Bucket Width	1,270mm(50")	1,524mm (60")
Bucket Weight	70kg (154.3 lbs)	76kg (167.5 lbs)
Approx. Weight (without Bucket)	295kg (650 lbs)	349kg (770 lbs)
Bucket Capacity	0.22m ³ (0.16m ³) 7.76 cu.ft (5.65 cu.ft)	0.27m ³ (0.20m ³)9.53cu.ft (7.06cu.ft.)

Specifications and design are subject to change without notice.



Backhoe Model : KB2475 Tractor Model : CK27/CK30/CK35

Backhoe

The sub-frame mounted KB Series backhoes can be easily attached and detached using locking pins and quick-connect hydraulics. The backhoe's offset sub-frame design provides a large approach angle for the easiest trailer loading in its class. The KB Series backhoes also feature responsive two-lever controls with exceptional feathering, hydraulic stabilizers, transport lock and a variety of heavy duty buckets.

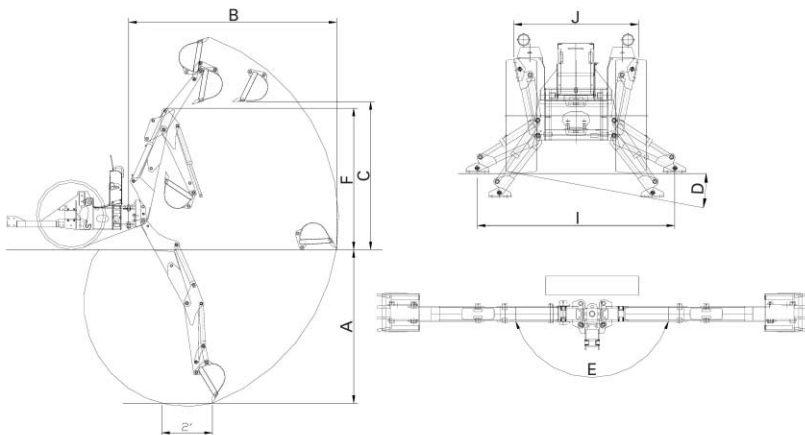

Backhoe Specifications

	KB2465	KB2475
A. Digging Depth (two foot flat bottom)	1940mm/76.3"	2,280mm/89.7"
B. Reach from Center Line of Swing Pivot	2875mm/113.1"	3,180mm/125.1"
C. Loading Height (bucket at 60°)	1615mm/63.6"	1,840mm/72.4"
D. Maximum Leveling Angle	10°	10°
E. Swing Arc	180°	180°
F. Transport Height (maximum)	1960mm/77.2"	2,120mm/83.5"
G. Transport Overhang	1105/43.5"	1,245mm/49.0"
H. Bucket Rotation	180°	180°
I. Stabilizer Spread (down position)	1745mm/68.7"	1,745mm/68.7"
J. Stabilizer Spread (up position)	1180mm/46.4"	1,180mm/46.4"
K. Angle of Departure	21°	21°
Shipping Weight - Backhoe (without bucket)	470 kg/1,036 lbs	485 kg/1,069 lbs
Bucket Digging Force	1278 kg/2817.5 lbs	1,278 kg/2,817.5 lbs
Dipperstick Digging Force	793 kg/1,748 lbs	955 kg/2,105 lbs
Operating Pressure	170 bar/2,466 psi	170 bar/2,466 psi

Cylinders

Cylinder	Bore DIA	Retracted Length	Stroke	Rod DIA
Boom	2.75	23	15.1	1.57
Bucket	2.36	21	11.7	1.38
Dipperstick	2.36	20.6	11.9	1.38
Swing	2.36	15.67	8.78	1.38
Stabilizer	2.36	17.5	10.31	1.38

Buckets

Bucket	Teeth Q'TY	Struck Capacity	Heaped Capacity	Shipping Weight
9" Bucket	3	0.73 cu. ft.	0.87 cu. ft.	46 lbs.
12" Bucket	3	1.01 cu. ft.	1.24 cu. ft.	56 lbs.
16" Bucket	3	1.38 cu. ft.	1.76 cu. ft.	64 lbs.
18" Bucket	4	1.56 cu. ft.	2.02 cu. ft.	70 lbs.
24" Bucket	5	2.11 cu. ft.	2.82 cu. ft.	94 lbs.
36" Bucket	6	2.78 cu. ft.	4.00 cu. ft.	114 lbs.

Specifications and design are subject to change without notice.

Specifications



ISO 9001
NO:954596



ISO 14001
NO:771475



OHSAS 18001
NO:K033008

MODEL	CK20S	CK20S HST	CK27	CK27 HST	CK30	CK30 HST	CK35	CK35 HST	
ENGINE									
Model	3C100LWB		3A139LWM	3A139LWH	3A150LWM	3A150LWH	3A165LWM	3A165LWH	
Type	3Cyl., In-line Vertical, Water-cooled 4-cycle diesel engine								
Engine gross HP(KW)	22(16.4)		28(20.9)		30(22.4)		34(25.4)		
PTO HP(KW)	17.1(12.8)	16.2(12.1)	21.7(16.2)	20.5(15.3)	23(17.2)	22(16.4)	27.6(20.6)	26.5(19.8)	
Displacement cu.in.(cc)	61.45(1,007)		85.0(1,393)		91.5(1,500)		100.5(1,647)		
Rated revolution rpm	2,800		2,600		2,600		2,600		
Fuel tank capacity u.s.gal(ℓ)	5.28(20)		7.9(30)		7.9(30)		7.9(30)		
DRIVE TRAIN									
Clutch	Dry single		Dry dual	Dry single	Dry dual	Dry single	Dry dual	Dry single	
Transmission	Manual	Hydrostatic	Synchro shuttle	Hydrostatic drive	Synchro shuttle	Hydrostatic drive	Synchro shuttle	Hydrostatic drive	
Speeds	6F2R	INF. 2	8F8R	INF. 3	8F8R	INF. 3	8F8R	INF. 3	
Differential lock	Standard		Standard		Standard		Standard		
Brake	Wet Disc		Wet Disc		Wet Disc		Wet Disc		
PTO	Transmission	Live	Live		Live		Live		
Rear(Optional)	540		540, (1,000)		540, (1,000)		540, (1,000)		
Mid(Optional)	(2,000)		(2,000)		(2,000)		(2,000)		
HYDRAULIC SYSTEM									
Pump	Gear		Gear(Tandem)		Gear(Tandem)		Gear(Tandem)		
Pump capacity(Max. flow rate) gpm(ℓ /min)	7.66(29)		12.7(48.3)		12.7(48.3)		12.7(48.3)		
3-point hitch	Cat. I		Cat. I		Cat. I		Cat. I		
Maximum lifting capacity(24" aft. of hitch) lbs.(kg)	1,305(592)		1,764(800)		1,764(800)		1,764(800)		
Hydraulic lift control system	position control								
Steering	Hydrostatic Power Steering								
TIRE SIZE									
Front AG.(TURF, INDUSTRIAL)	6-12(23 × 8.5-12, 23 × 8.5-12)				7-14(27 × 8.50-15, 25 × 8.50-14)				
Rear AG.(TURF, INDUSTRIAL)	9.5-16(33 × 12.5-16.5, 12-16.5)				11.2-24(41 × 14.00-20, 15-19.5)				
TRAVELING SPEEDS									
Forward mph(km/h)	0.68-10.08 (1.10-16.22)	0-9.30 (0-14.97)	0.98-14.91 (1.57-24.00)	0-13.07 (0-21.03)	0.98-14.91 (1.57-24.00)	0-13.07 (0-21.03)	0.98-14.91 (1.57-24.00)	0-13.07 (0-21.03)	
Reverse mph(km/h)	0.85-3.91 (1.36-6.30)	0-6.51 (0-10.48)	0.86-13.14 (1.38-21.15)	0-9.15 (0-14.72)	0.86-13.14 (1.38-21.15)	0-9.15 (0-14.72)	0.86-13.14 (1.38-21.15)	0-9.15 (0-14.72)	
DIMENSIONS									
Overall length(includes 3-pt hitch) in.(mm)	105.7(2,684)				122.2(3,103)				
Overall width(minimum tread) in.(mm)	44.1(1,121)				54.6(1,387)				
Overall height(from top of ROPS) in.(mm)	86.0(2,185)				96.8(2,460)				
Wheelbase in.(mm)	57.9(1,470)				66.1(1,680)				
Min. ground clearance in.(mm)	12.2(310)				13.82(351)				
Tread	Front in.(mm)	35.8(910)				43.5(1,105)			
	Rear in.(mm)	35.0-36.8(890-935)				38.2-51.3(970-1,302)			
Min. turning radius(with brake) feet(m)	7.5(23)				9.5(2.9)				
Weight with ROPS lbs.(kg)	2,125(964)	2,138(970)	3,161(1,434)	3,117(1,414)	3,184(1,445)	3,142(1,426)	3,151(1,430)	3,114(1,413)	

Specifications and design are subject to change without notice.

Standard Equipment

- Foldable ROPS
- Power Steering
- Differential Lock
- Rear PTO 540 rpm
- Single Lever Joystick Control for Loader Operation
- Head Lights/ Safety Lights
- Wet Disc Brakes
- 3 Point Hitch Speed Control
- Fully Adjustable 3 Point Hitch
- Safety Start switch
- Cruise Control (HST models)
- Adjustable seat with Seat Belt
- Bevel Gear Type Front Axle

CK27/CK30/CK35

- Telescopic Link Ends
- Tilt Steering Wheel
- Removable Drawbar

Optional Equipment

- Single Remote Hydraulic Valve
- Mid PTO
- Front Weights
- Rear Working Light
- Sunshade

CK27/CK30/CK35

- Second Remote Hydraulic Valve
- Rear PTO 1000 rpm
- Rear Weights (Ag Tires only)

Available KIOTI

Attachments & Implements

- Front End Loader
- Backhoe
- Mower
- Tiller



KIOTI Tractor Division

DAEDONG - USA, INC.
6300 KIOTI Drive, Wendell, NC 27591
toll free 877-GO-KIOTI fax 919-374-5001
web www.KIOTI.com

Dealer Imprint Area

Part Number LIT-CK-ALL